



REPLY TO
ATTENTION OF

DEPARTMENT OF THE ARMY
THE INSTITUTE OF HERALDRY
9325 GUNSTON ROAD, ROOM S112
FORT BELVOIR, VIRGINIA 22060-5579

DEC 23 2016

AAHS-IHS (840-10a)

MEMORANDUM THRU Chief, National Guard Bureau, ATTN: NGB-PAH (Mr. Nestell),
1411 Jefferson Davis Highway, Arlington, VA 22202-3231

FOR Commander, HHC, 219th Engineer Brigade, ATTN: MAJ Amber Anderson,
Johnson County Armory, 325 Minuteman Way, Franklin, IN 46131

SUBJECT: Heraldic Items for the 219th Engineer Brigade, Indiana Army National
Guard

1. As a result of the redesignation of the 219th Battlefield Surveillance Brigade to the 219th Engineer Brigade, the distinctive unit insignia (DUI) and shoulder sleeve insignia (SSI) have been redesignated as outlined in enclosures 1 and 2.

2. Also enclosed are the following:

a. Manufacturing drawing, black and white line drawing, and color print for the DUI (encls 3-5).

b. SSI manufacturing drawing (A-1-959) and color print (with the subdued and line drawing) (encls 6 and 7).

c. Manufacturing drawing, black and white line drawing, and color print of the Combat Service Identification Badge (CSIB) (encls 8-10)

3. The Brigade flag will be divided vertically scarlet and white with yellow fringe and the SSI centered as shown on enclosure 11. The U.S. Army Tank-Automotive and Armaments Command is responsible for the procurement of flags. To obtain your flag, complete DD Form 1348-6 on line at www.heraldry.army.mil; citing TIOH Drawing No. 5-1-310 and A-1-959, in the remarks section. POC at the Clothing and Heraldry Office is Ms. Franklin, DSN 444-2515 or COMM (215) 737-2515.

4. You may retain the 219th Battlefield Surveillance Brigade flag as a historical item. POC is Institute is Mrs. Henning by email at bonnie.s.henning.civ@mail.mil or by telephone at DSN 656-4972, COMM (703) 806-4972.

11 Encls
as

MUGNO.CHARLES.V.
.1020723374

CHARLES V. MUGNO
Director

Digitally signed by
MUGNO.CHARLES.V.1020723374
DN: c=US, o=U.S. Government, ou=DoD, ou=PKI,
ou=USA, cn=MUGNO.CHARLES.V.1020723374
Date: 2016.12.23 11:17:43 -0500



REPLY TO
ATTENTION OF

DEPARTMENT OF THE ARMY
THE INSTITUTE OF HERALDRY
9325 GUNSTON ROAD, ROOM S112
FORT BELVOIR, VIRGINIA 22060-5579

AAHS-IHS (840-10a)

DEC 23 2016

MEMORANDUM FOR Commander, HHC, 219th Engineer Brigade, ATTN: MAJ Amber Anderson, Johnson County Armory, 325 Minuteman Way, Franklin, IN 46131

SUBJECT: Distinctive Unit Insignia for the 219th Engineer Brigade, Indiana Army National Guard

1. The distinctive unit insignia (DUI) redesignated effective 1 September 2016, for the 219th Engineer Brigade, was:

a. **Originally authorized** for the 219th Support Group by letter JDRP-IH-HS, The Institute of Heraldry, 16 August 2005.

b. **Redesignated** effective 1 September 2008, for the 219th Battlefield Surveillance Brigade and amended to revise the symbolism by letter AAHS-IHS, The Institute of Heraldry, 31 January 2008.

2. The description and symbolism of the design are as follows:

DESCRIPTION

A gold color metal and enamel device 1 1/8 inches (2.86 cm) in height consisting of a scarlet shield bearing the face of a snarling tiger detailed in black, scarlet, and gold brown. Enclosing the base of the device a black bipartite motto scroll doubled gold inscribed "EYE OF THE TIGER" in gold metal letters.

SYMBOLISM

The face of the tiger recalls the Group's motto, "Eye of the Tiger." The shield shape of the device symbolizes protection and defensive support. The colors, buff, here represented as gold, and scarlet, refer to Support branch colors, the original designation of the unit. Black denotes strength and solidarity and recalls the markings of the tiger. Gold also signifies honor and excellence.

AAHS-IHS (840-10a)

SUBJECT: Distinctive Unit Insignia for the 219th Engineer Brigade, Indiana Army National Guard

3. This authorization is in accordance with AR 670-1 and National Guard Bureau Organizational Authority Number 288-16, dated 18 August 2016. A copy of this letter will become part of your permanent organizational history files.

MUGNO.CHARLES.V.1
020723374

Digitally signed by MUGNO.CHARLES.V.1020723374
DN: c=US, o=U.S. Government, ou=DoD, ou=PKI,
ou=USA, cn=MUGNO.CHARLES.V.1020723374
Date: 2016.12.23 11:17:09 -0500

CHARLES V. MUGNO
Director

CF: CMH



REPLY TO
ATTENTION OF

DEPARTMENT OF THE ARMY

THE INSTITUTE OF HERALDRY
9325 GUNSTON ROAD, ROOM S112
FORT BELVOIR, VIRGINIA 22060-5579

AAHS-IHS (840-10a)

DEC 23 2016

MEMORANDUM FOR Commander, HHC, 219th Engineer Brigade, ATTN: MAJ Amber Anderson, Johnson County Armory, 325 Minuteman Way, Franklin, IN 46131

SUBJECT: Shoulder Sleeve Insignia for the 219th Engineer Brigade, Indiana Army National Guard

1. The shoulder sleeve insignia redesignated effective 1 September 2016, for the 219th Engineer Brigade with the symbolism updated, was **originally authorized** for the 219th Battlefield Surveillance Brigade by letter AAHS-IHS, The Institute of Heraldry, 28 February 2008.
2. The description and symbolism of the design are as follows:

DESCRIPTION

On a vertically divided through the center arrowhead-shaped item, blue and red, displaying in the center a vertical black sword, edged yellow and pointed up, superimposed across the top by three yellow lightning bolts, diagonally from right to left, the middle lightning bolt surmounting the blade; all within a 1/8 inch (.32 cm) black border. Overall dimensions are 3 1/8 inches (7.94 cm) in height and 2 3/4 inches (6.99 cm) in width.

SYMBOLISM

The arrow-shaped insignia, adapted from the U.S. Recondo School, highlights the Recondo/Reconnaissance philosophy of integrity, developing the traits of smart, skilled, tough, courageous, and confident Soldiers. The divided background colors of blue and red signify the unit's lineage to the 38th Infantry Division. The black sword outlined in yellow emphasizes the stealth required for proper intelligence collection, indicating missions along the forward edge of the battlefield and the Brigade's readiness to sustain the tip of the battlefield. The lightning bolts symbolize the three tenants of the former Battlefield Surveillance Brigade's responsibilities of intelligence, surveillance, and reconnaissance.

3. This letter also serves to redesignate the Combat Service Identification Badge.

AAHS-IHS (840-10a)

SUBJECT: Shoulder Sleeve Insignia for the 219th Engineer Brigade, Indiana Army National Guard

4. This authorization is in accordance with AR 670-1 and National Guard Bureau Organizational Authority 288-16, dated 18 August 2016. A copy of this letter will become part of your permanent organizational history files.

MUGNO.CHARLES.V.1
020723374

Digitally signed by MUGNO.CHARLES.V.1020723374
DN: c=US, ou=U.S. Government, ou=DoD, ou=PKI,
ou=JSA, cn=MUGNO.CHARLES.V.1020723374
Date: 2016.12.23 11:16:46 -0500

CHARLES V. MUGNO
Director

CF: CMH

FOR SUBDUED INSIGNIA

ACU-UCP:

RED & BLUE AREAS TO BE FOLIAGE GREEN
67202. BLACK & YELLOW AREAS TO BE
BLACK 67138.

ACU-OCP:

RED & BLUE AREAS TO BE BAGBY GREEN
67204. BLACK & YELLOW AREAS TO BE
BLACK 67138.

REVISIONS

LTR	DESCRIPTION	DATE	APPROVED
-----	-------------	------	----------

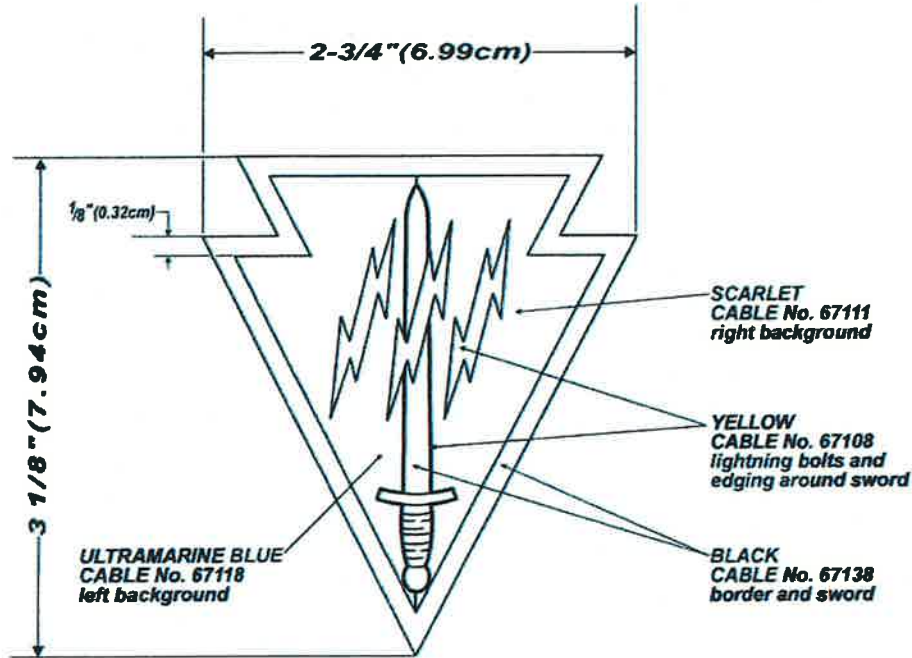

DESIGNED FOR OVEREDGE STITCHING

STITCH COUNT

5614 STITCHES (minimum)
90/2 DENIER
12/4 SPAN

SUPERSEDES TIOH DWG No. A-1-959 DTD. 20 FEBRUARY 2008

UNLESS OTHERWISE SPECIFIED DIMENSIONS ARE IN INCHES TOLERANCES ON FRACTIONS DECIMALS ANGLES

MATERIALS:
TO BE MANUFACTURED IN ACCORDANCE WITH MIL-DTL-14652

EXAMINED	TLC
CHECKED	SAO
PREPARED	CA

APPROVED
MUGNO.CHARLES.V.10
20723374

CHARLES V. MUGNO
DIRECTOR

THE INSTITUTE OF HERALDRY, DEPARTMENT OF THE ARMY
9325 GUNSTON RD. S-113 FORT BELVOIR, VA 22060-5579

SHOULDER SLEEVE INSIGNIA

219TH ENGINEER BRIGADE

SIZE CONTROL IDENT. NO
A 22571 A - 1 - 959

SCALE FULL DATE 19 DECEMBER 2016



COLOR



ACU-UCP



ACU-OCP

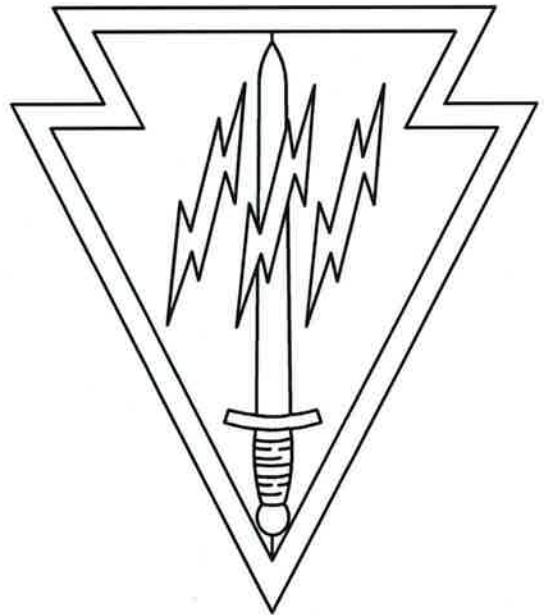

LINE

SHOULDER SLEEVE INSIGNIA
219TH ENGINEER BRIGADE



219TH ENGINEER BRIGADE

****This Drawing is 6X Actual size****

TYPE II D-6614

ACTUAL SIZE-----1 1/8" ± 1/64" Wide (2.86cm ± .04cm)

METAL COLOR
& PLATING-----Gold
FINISH-----Mirror-like polish

DESIGN:
CHARGES-----Flush, except ends of scroll to be recessed and modeled.

LETTERING-----Finish metal
PIERCING-----None, recessed and textured between shield and scroll.

EPOXY-----Stoning

CHIP Nos-----Red #1, Black #26, Transparent Gold #36

APPROVED DEC 23 2016
THE INSTITUTE OF HERALDRY
DEPARTMENT OF THE ARMY

MUGNO.CHARLES.V.1
020723374

Digitally signed by MUGNO CHARLES.V.1020723374
DN: cn=US, o=U.S. Government, ou=DoD, ou=PKI,
ou=USA, cn=MUGNO CHARLES.V.1020723374
Date: 2016.12.23 11:16:03 -05'00'

CHARLES V. MUGNO
DIRECTOR



219TH ENGINEER BRIGADE

****This Drawing is 6X Actual size****

TYPE II D-6614

ACTUAL SIZE-----1 1/8" ± 1/64" Wide (2.86cm ± .04cm)

METAL COLOR
& PLATING-----Gold
FINISH-----Mirror-like polish

DESIGN:
CHARGES-----Flush, except ends of scroll to be recessed and modeled.

LETTERING-----Finish metal
PIERCING-----None, recessed and textured between shield and scroll.

EPOXY-----Stoning

CHIP Nos-----Red #1, Black #26, Transparent Gold #36

APPROVED **DEC 23 2016**
THE INSTITUTE OF HERALDRY
DEPARTMENT OF THE ARMY

MUGNO.CHARLES.V.1
020723374

Digitally signed by MUGNO.CHARLES.V.1020723374
DN: c=US, o=U.S. Government, ou=DoD, ou=PKI,
ou=USA, cn=MUGNO.CHARLES.V.1020723374
Date: 2016.12.23 11:15:45 -0500

CHARLES V. MUGNO
DIRECTOR



219TH ENGINEER BRIGADE

****This Drawing is 6X Actual size****

ACTUAL SIZE-----1 1/8" ± 1/64" Wide (2.86cm ± .04cm)

METAL COLOR

& PLATING-----Gold

FINISH-----Mirror-like polish

DESIGN:

CHARGES-----Flush, except ends of scroll to be recessed and modeled.

LETTERING-----Finish metal

PIERCING-----None, recessed and textured between shield and scroll.

EPOXY-----Stoning

CHIP Nos-----Red #1, Black #26, Transparent Gold #36

TYPE II D-6614

***For Color Placement Only
Not For Color Match***

DEC 23 2016

**APPROVED
THE INSTITUTE OF HERALDRY
DEPARTMENT OF THE ARMY**

**MUGNO.CHARLES.V.1
020723374**

Digitally signed by MUGNO.CHARLES.V.1020723374
DN: cn=US, ou=U.S. Government, ou=DoD, ou=PKI,
ou=USA, cn=MUGNO.CHARLES.V.1020723374
Date: 2016.12.23 11:15:26 -0500

**CHARLES V. MUGNO
DIRECTOR**

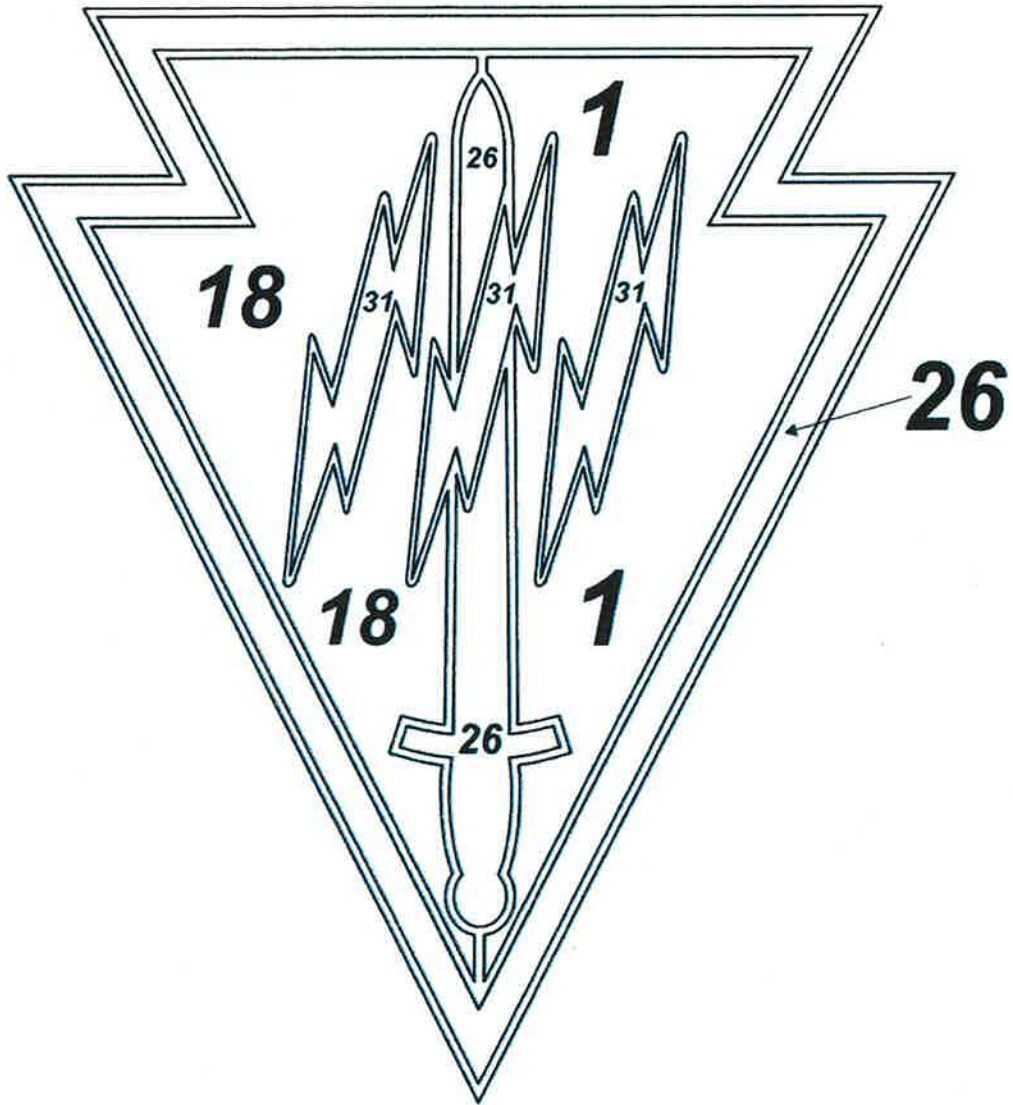

TYPE I C-1147

219TH ENGINEER BRIGADE

****This Drawing is 3x-Actual Size****

ACTUAL SIZE-----2" ± 1/64" High (5.08 cm ± 0.04 cm)

METAL COLOR
AND PLATING-----Gold
FINISH-----Mirror-like polish

DESIGN:
CHARGES-----Flush
LETTERING-----None
PIERCING-----None.
PRONGS-----Three (3)
EPOXY-----Stoning

CHIP No's-----Red #1, Blue #18, Black #26, Yellow #31

DEC 23 2016

APPROVED
THE INSTITUTE OF HERALDRY,
DEPARTMENT OF THE ARMY

MUGNO.CHARLES.V.102
0723374

Digitally signed by MUGNO.CHARLES.V.1020723374
DN: ce=US, o=U.S. Government, ou=DoD, ou=PKI,
ou=USA, cn=MUGNO.CHARLES.V.1020723374
Date: 2016.12.23 11:15:08 -05'00'

CHARLES V. MUGNO
DIRECTOR

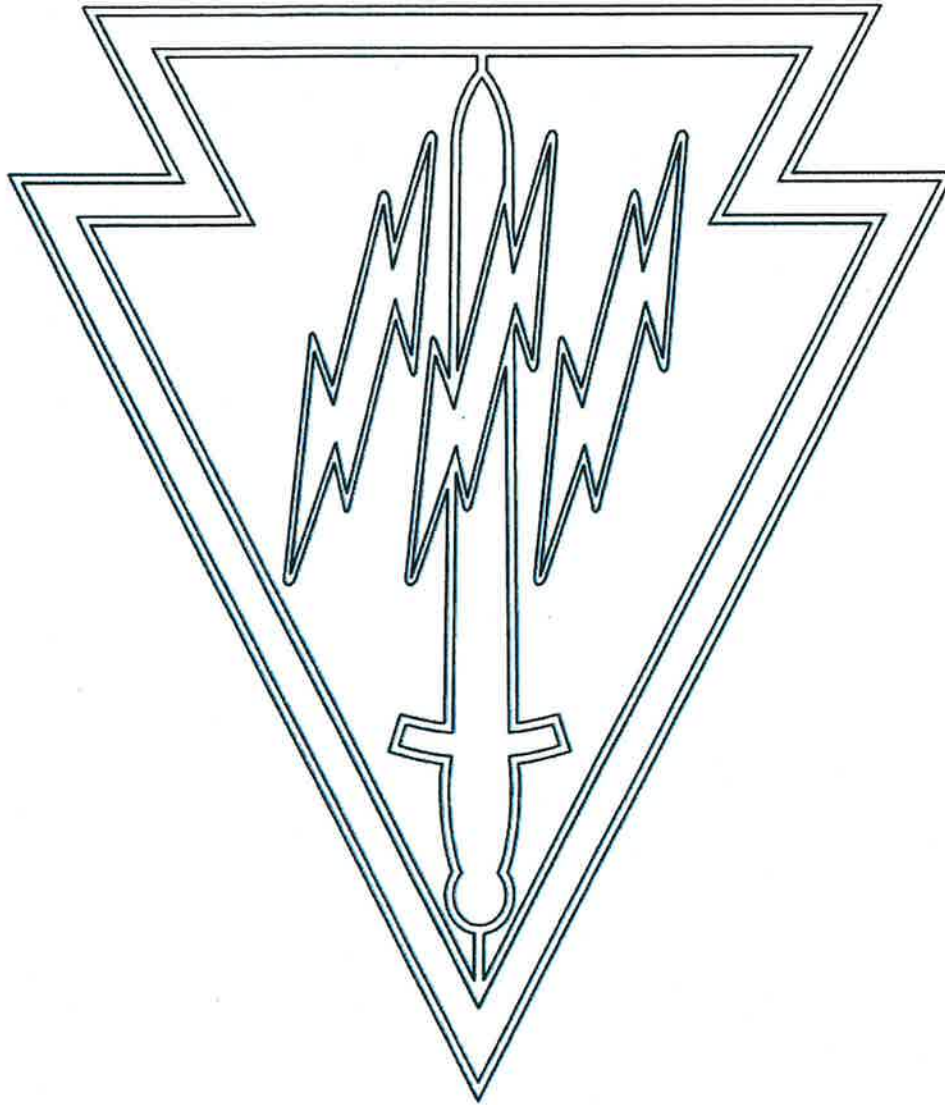

TYPE I C-1147

219TH ENGINEER BRIGADE

****This Drawing is 3x-Actual Size****

ACTUAL SIZE-----2" ± 1/64" High (5.08 cm ± 0.04 cm)

METAL COLOR
AND PLATING-----Gold
FINISH-----Mirror-like polish

DESIGN:
CHARGES-----Flush
LETTERING-----None
PIERCING-----None.
PRONGS-----Three (3)
EPOXY-----Stoning

CHIP No's-----Red #1, Blue #18, Black #26, Yellow #31

APPROVED DEC 23 2016
THE INSTITUTE OF HERALDRY,
DEPARTMENT OF THE ARMY

MUGNO.CHARLES.V.102 Digitally signed by MUGNO.CHARLES.V.1020723374
0723374 DN: cn=US, ou=U.S. Government, ou=DoD, ou=PKI,
ou=USA, c=MUGNO.CHARLES.V.1020723374
Date: 2016.12.23 11:14:50 -05'00'

CHARLES V. MUGNO
DIRECTOR



219TH ENGINEER BRIGADE

****This Drawing is 3x-Actual Size****

ACTUAL SIZE-----2" ± 1/64" High (5.08 cm ± 0.04 cm)

METAL COLOR
AND PLATING-----Gold
FINISH-----Mirror-like polish

DESIGN:
CHARGES-----Flush
LETTERING-----None
PIERCING-----None.
PRONGS-----Three (3)
EPOXY-----Stoning

CHIP No's-----Red #1, Blue #18, Black #26, Yellow #31

TYPE I C-1147

***For Color Placement Only
Not For Color Match***

APPROVED **DEC 2 3 2016**
THE INSTITUTE OF HERALDRY,
DEPARTMENT OF THE ARMY

MUGNO.CHARLES.V.
1020723374

Digitally signed by MUGNO.CHARLES.V.1020723374
DN: c=US, o=U.S. Government, ou=DoD, ou=PKI,
ou=USA, cn=MUGNO.CHARLES.V.1020723374
Date: 2016.12.23 11:14:33 -0500

CHARLES V. MUGNO
DIRECTOR



THE INSTITUTE OF HERALDRY
9325 GUNSTON ROAD
FORT BELVOIR, VIRGINIA 22060-5579

COMBAT SERVICES IDENTIFICATION BADGE

219TH ENGINEER BRIGADE

19 DECEMBER 2016



CoALFORD



THREE TIMES



ACTUAL SIZE

CSIB
219TH ENGINEER BRIGADE

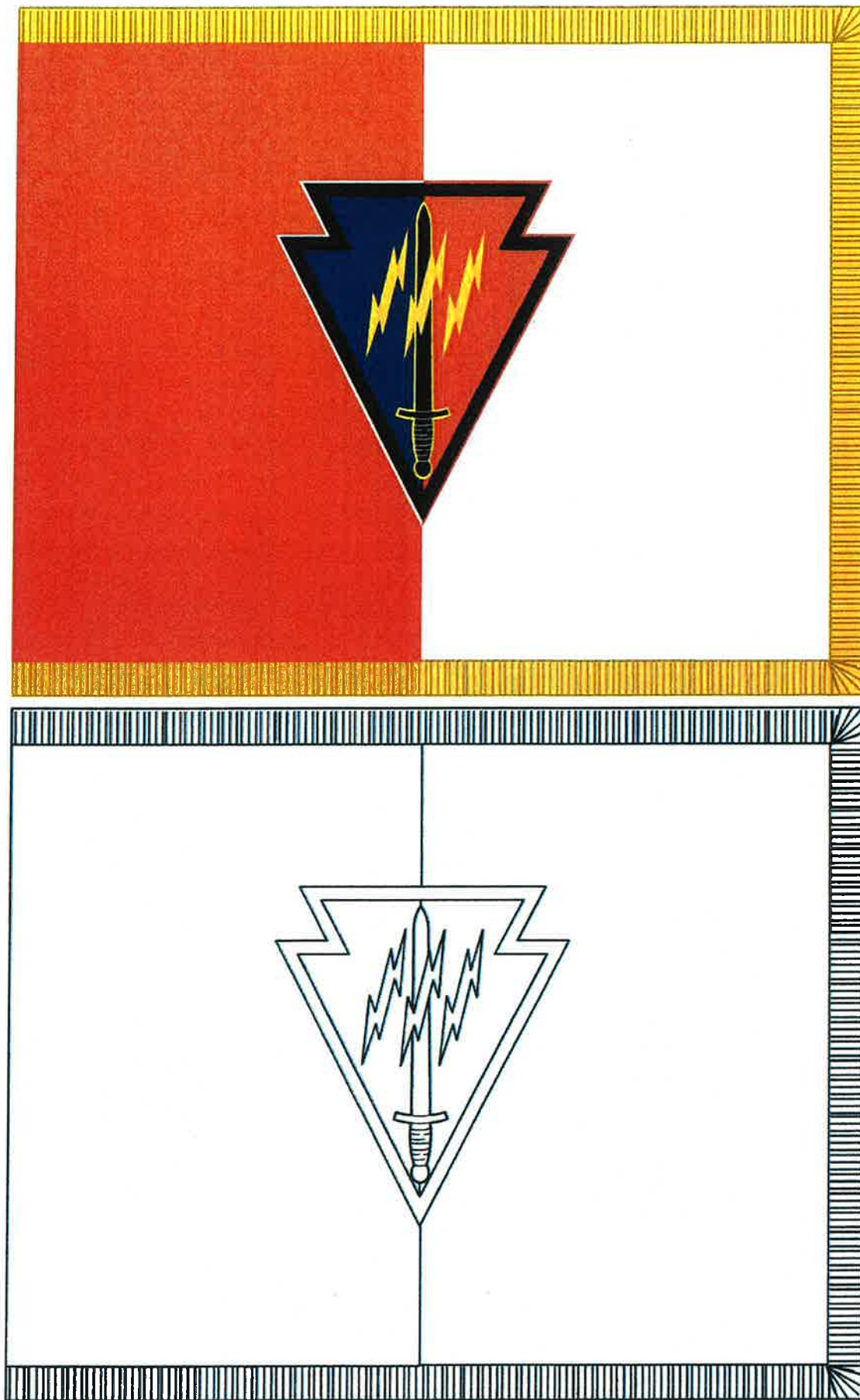

FLAG
219TH ENGINEER BRIGADE